 <p>Durga Engineering works C-901, Concord Proxima, Baner road, Pune 411045</p> <p>Durga Engineering Co. Jay Shukla Mobile No. 97308 33500 Mail id : Manufacturing.durga@gmail.com Mahesh Shukla Mobile No. 96230 33500 Mail id : durga.enterprisetrd@gmail.com</p>	Data Sheet	Data Sheet No : 01-008	ISO 9001 Registered
		Revision : 00	
		Page : 1 of 1	

Calibration Pot - DCP

It is an easy & economical method of checking the flow rate of chemical metering pumps.

Construction :

It is available in two types of constructions **Type S** (fig 1) & **Type L** (fig 2) depending on their capacities.

Type S are designed for volume capacities upto 5000ml. It consists of a glass measuring jar held between two holding flanges through tie rods with suitable gaskets to provide leakproof joint and provided with process flanges at top and bottom. The measuring jar is calibrated for volume and provided with volumetric scale in milliliters . It is protected by a stainless steel shield with a front opening to provide visual indication.

Type L are designed for higher volume capacities upto 20000ml. It consists of stainless steel measuring jar held between two holding flanges and provided with process flanges at top & bottom. A tubular glass gauge with acrylic shield is mounted in front for visual indication. The measuring jar is calibrated for volume and provided with volumetric scale in milliliters on front gauge glass.

Specifications :

Construction	Type S	Type L
Measuring jar	Tempered Borosilicate Glass	SS304/316
Volume Capacity (ml)	100 to 20000ml	
Gasket/ Packing	Viton	
Wetted Parts MOC	SS304, SS316	
Tie Rods	SS304	NA
Protection Shield	SS304	Acrylic
Calibrated Scale	Polycarbonate with black graduations & numericals	
Max. Temperature	70°C	
Max. Pressure	1 Kg/cm ²	5Kg/cm ²



Type S

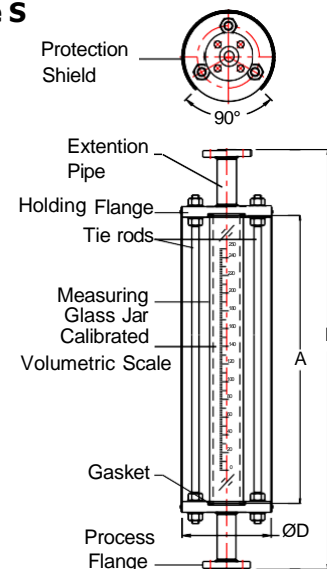

Fig. 1

Type L

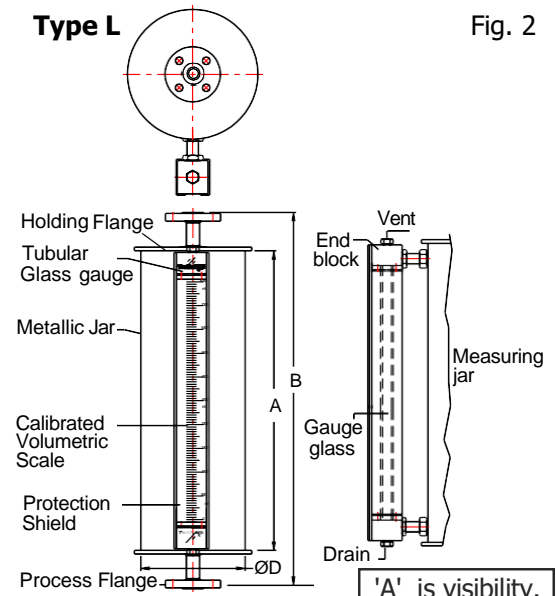

Fig. 2

Volume Capacity Vs Dia of Measuring Jar x FF Distance :

Type 'S'			Type 'L'		
Vol. Cap. (ml) 'V'	Dia of measuring jar (mm) - 'D'	F F Dist (mm) 'B'	Vol. Cap. (ml) 'V'	Dia of measuring jar (mm) - 'D'	F F Dist (mm) 'B'
100	28	430	6000	168	535
200	38	430	8000	168	610
250	38	485	9000	168	660
500	60	410	10000	168	710
1500	90	500	20000	273	585
2000	115	415			
2500	115	470			
4000	163	425			
5000	163	482			

Installation and Operation: Fig. 3

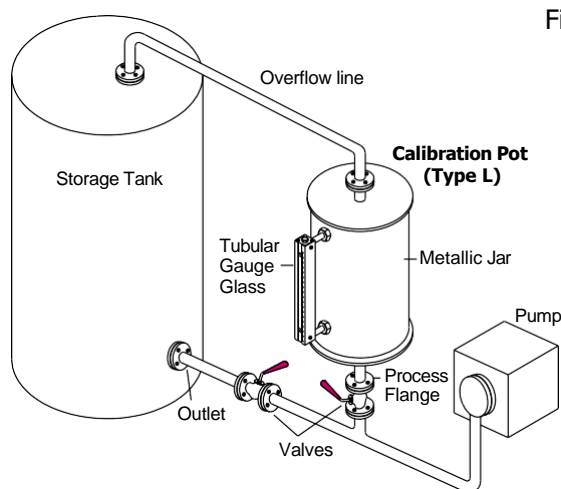

Fig. 3

CP is installed between the suction side of a chemical pump and storage tank. The system is provided with valve on outlet of storage tank and inlet of calibration pot. The pumping flow rate (ml/min) can be checked by observing change in liquid volume in calibration jar for a fixed time period with 'Pump -On'. Pump flow rate verification on a periodic basis & especially after maintenance is very essential for system accuracy.

Applications :

Metering / Dosing Pumps in Waste Water Treatment Plants, Treatment Plants, Pharmaceuticals and Chemical Industries.

Model identification :

CP- x Capacity

Construction

Glass Measuring Jar — S

SS Measuring Jar — L

Process Connection

(Pr. Conn, & holding flgs)

15 NB ANSI Flange — 1

25NB ANSI Flange — 2

Others — 0

Wetted Parts

SS304 — N

SS316 — S

Others — O

Counter Flanges

Not Provided — W

Provided — Y

Ordering Information :

Model no. x capacity along with Liquid, Optg. Temp. & Pressure